

关注公众号



MPAPOWER[®]

高压流体控制系统专业解决方案
High Pressure Fluid Control Solutions

MPAPOWER[®]

HIGH PRESSURE PUMPS
超高压电动泵

HIGH PRESSURE ELECTRIC PUMPS
超高压电动泵

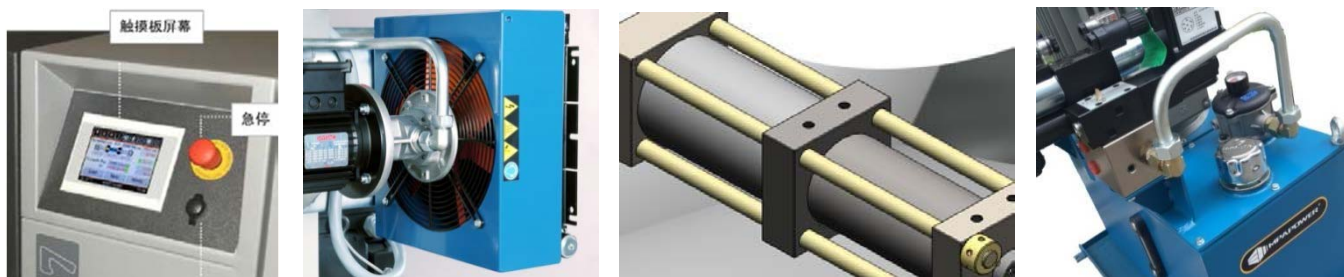

上海兆帕流体动力有限公司成立于 2004 年。

我们作为中国工业控制测量和控制标准化技术委员参与国家标准建设，做出了应有的贡献。

公司定位为高压流体系统专业供应商，专注于为客户提供压力相关系统解决方案，不管是气、水、油，还是二氧化碳、冷媒等各类特殊介质，从真空到 700MPa 超高压，从压力测试到爆破、脉冲试验，从冷媒集中供料到高压液相色谱装柱，从氮气增压到撬装加氢，我们都有成熟的系统解决方案。

我们具有多年的行业服务经验，灵活的非标定制能力和快速的交付能力，广泛服务航空航天、石油化工、核能核电、船舶重工、家电、汽车和新能源等领域。

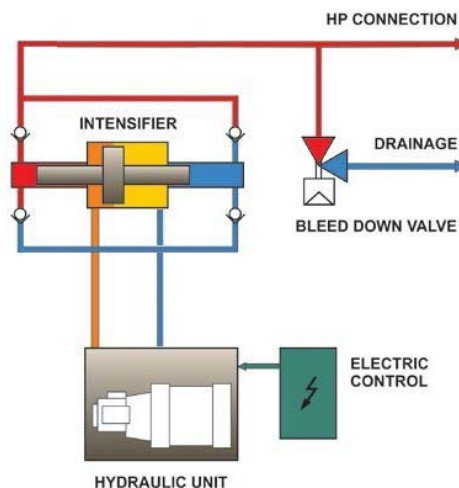

上海兆帕流体动力有限公司

Shanghai MPA Fluid Power Co.,Ltd

Tel: +86 21 5843 0335 Fax: +86 21 3378 1356

E-mail:info@mpapower.com Website: www.mpapower.com

HIGH PRESSURE PUMPS ARE CHARACTERIZED BY THE FOLLOWING FEATURES

特性

最高输出压力可达 400MPa。

输出压力可无级线性调节

双级设计，可实现高低压泵同时供油，低压输出大流量，高压输出小流量。

双重溢流阀，内置溢流阀用于出厂前设定过载保护，外置溢流阀用于用户调节系统输出压力，实现无级高精度压力调节。

不同于市场上的其他产品，自带散热器，保证泵站可长时间、高频率使用，具有足够的抗冲击力和平稳的压力输出。

含高压压力表和泄压阀。

3D 工业设计，集成在可移动的密封箱体内部，内部元件不易损伤

牢固，安全，可靠，结构紧凑。

可根据需要采用计算机控制，压力数字显示，操作人员可通过计算机界面实现对整个系统进行控制。

除表中所列型号，我们可根据客户需求灵活定制不同压力，不同流量，不同外形尺寸，不同控制方式的产品

常用于用于高速动车组、城轨车辆的车轮及制动盘拆装，过盈配合类变速箱齿轮的拆装。



BASIC EQUIPMENT

The basic design of this high pressure pump includes a complete hydraulic drive unit with oil/air cooler, high pressure intensifier, and bleed down valve. The operating pressure is controlled by proportional valve and continuously adjustable between 20 and 400 MPa. All hydraulic and high pressure components are mounted on a base frame and covered by a sound insulated housing. The electric control is installed inside a switch box attached to the basic frame of the pump.

OPTIMIZED HYDRAULIC SYSTEM

The hydraulic unit is characterized by highly dynamic controls. Use of a soft-switching hydraulic valve with specially designed control geometry guarantees extremely short switch-over times. Oil filtering and cooling take place via the axial piston pump of the hydraulic drive. The excellent oil quality this achieves has a positive influence on operational safety and the life expectancy of the whole hydraulic system.

OIL COOLING

Oil/air as well as oil/water cooler are available as standard and installed on the base frame inside the pump housing. If the ambient temperature is lower than 35°C, an air cooler may be used. This eliminates the entire cooling water requirements. For higher temperatures the water cooler is available. Cooling water flow is controlled via thermostat.

THE PRESSURE INTENSIFIER

The high pressure components in the intensifier are characterized by a long life expectancy. Besides the special steels developed specifically for this application, Thanks to the special design, the intensifier is easy to maintain. Wearing parts like seals and check valves can be replaced quickly and easily.

PRESSURE ADJUSTMENT

Electronic pressure adjustment via relief valve is standard. proportional valve is optional too. So the working pressure is adjustable at the operating panel directly at the pump or via external analog signal from 4 to 20mA.

BLEEDING VALVE

This pressure release valve is installed within the high pressure line of the pump.

On request, any flow, any diameter and any control way are available for your inquiry.

Model Selection:

型号

Technical Data 技术参数		E4001	E4003	E4005
Power supply, main motor 功率	kW	1.5	4	7.5
Flow rate, max. 流量	l/min	0.1	0.3	0.5
Design pressure 设计压力	MPa	400	400	400
Permissible operating pressure 允许工作压力	MPa	20~300	20~400	20~400
Oil tank volume 油箱容积	l	30	60	60
Ambient temperature with oil/air cooler 环境温度	°C	10-35	10-35	10-35
Supply voltage 电压	V	400	400	400
Frequency 频率	Hz	50	50	50
Width 长度	mm	500	800	800
Depth 宽度	mm	500	500	500
Hight 高度	mm	600	1000	1000
Total weight 重量	kg	100	120	180
Sound level, max. 噪音	dB(A)	≤ 79	≤79	≤ 79

